

**MAX**<sup>®</sup>

# PJID143

CORDLESS BRUSHLESS IMPACT DRIVER

OPERATING and MAINTENANCE MANUAL



Original instructions



**WARNING**

**BEFORE USING THIS TOOL, STUDY THIS MANUAL TO ENSURE SAFETY WARNING AND INSTRUCTIONS. KEEP THESE INSTRUCTIONS WITH THE TOOL FOR FUTURE REFERENCE.**

APRIL 2012

### 3. SPECIFICATIONS AND TECHNICAL DATA

#### 1. NAME OF PARTS (See Fig. A, B and C)

Fig. A	1	SLEEVE PROTECTOR
	2	TRIGGER SWITCH
	3	WARNING LABEL
	4	LED LAMP
	5	BATTERY PACK JPL914
	6	BELT HOOK
	7	CARRYING STRAP
	8	ROTATIONAL DIRECTION SWITCH
	9	BRUSHLESS MOTOR
	10	PROTECTOR
	11	BIT
	12	SCREW
	13	SPECIFICATION LABEL
	14	SERIAL NO.

Fig. B	15	PACK CAP
	16	TERMINAL
	17	VENTILATOR
	18	LATCH
Fig. C	19	SPECIFICATION LABEL
	20	BATTERY PACK ENTRY POINT
	21	LED LAMP (ORANGE) CHARGING STATUS INDICATOR LAMP
	22	LED LAMP (RED / GREEN) CHARGING STATUS INDICATOR LAMP
	23	SPECIFICATION LABEL
	24	VENTILATOR
	25	CE (VDE) POWER PLUG
	26	POWER CORD

#### 2. TOOL SPECIFICATIONS <Tool>

PRODUCT NO.	PJID143
WEIGHT	1.45kg(3.2lbs.) (Battery included)
HEIGHT	236mm (9-1/4")
WIDTH	82mm (3-1/4")
LENGTH	135mm (5-1/4")
RATED VOLTAGE / BATTERY	14.4V, Li-ion Battery pack JPL914
NO-LOAD SPEED	0~2,600 min-1
IMPACT RATE	0~2,500 min-1
MAXIMUM TORQUE (M14 HIGH TENSILE BOLT)	150Nm
MOTOR	Brushless DC Motor
OPERATING TEMPERATURE	0°C to 40°C (32°F to 104°F)
OPERATING HUMIDITY	80% RH or less

#### <Battery charger>

PRODUCT NAME	MAX lithium ion battery charger
PRODUCT NO.	JC928(CE)
INPUT	AC100-240V 50/60Hz 1.62-0.68A
OUTPUT	DC 7.2/10.8/14.4V 7A DC 18/21.6/25.2/28.8V 3.9A
WEIGHT	1.6kg (3.5lbs.)
OPERATING TEMPERATURE	5°C to 40°C (41°F to 104°F)
OPERATING HUMIDITY	80% RH or less

#### APPLICABLE FASTENER SPECIFICATIONS

Machine Screw	4mm~8mm
Standard Bolt	M5~M14
High Tensile Bolt	M5~M12

#### <Battery pack>

PRODUCT NAME	MAX lithium ion battery pack
PRODUCT NO.	JPL914
BATTERY TYPE	Lithium ion battery
NOMINAL VOLTAGE	DC14.4 V
NOMINAL CAPACITY	3.0 Ah (3,000 mAh)
CHARGING TIME (USE WITH JC928(CE))	Quick charging - Approximately 30 minutes (Apprx. 90% of capacity) Full charging - Approximately 45 minutes at 25°C(77°F) (100% of capacity)
ACCESSORIES	Pack cap (For preventing short circuit)
WEIGHT	0.5 kg (1.1lbs.)
CHARGING TEMPERATURE	5°C to 40°C (41°F to 104°F)
OPERATING TEMPERATURE	0°C to 40°C (32°F to 104°F)
OPERATING HUMIDITY	80% RH or less

#### BATTERY CHARGER:

Use only an authorized Battery charger, MAX JC928

#### 3. TECHNICAL DATA

##### ① NOISE

The typical A-weighted noise level determined according to EN60745-2-2:

- Sound pressure level ( $L_{pA}$ ): 88dB (A)
- Sound power level ( $L_{WA}$ ): 99dB (A)
- Uncertainty (K): 3dB (A)



##### ② VIBRATION

The vibration total value (tri-axial vector sum) determined according to EN60745-2-2:

- Work mode: Impact tightening of fasteners of the maximum capacity of the tool.
- Vibration emission value ( $a_h$ ): 9.6m/s<sup>2</sup>
- Uncertainty (K): 1.5m/s<sup>2</sup>

##### ③ RADIATED EMISSION 30-1000 MHZ

Class B

##### ④ Overvoltage category

PRODUCT	Overvoltage category
PJID143 CORDLESS BRUSHLESS IMPACT DRIVER	Category 1 according to IEC 60664-1
JC928(CE) BATTERY CHARGER	Category 2 according to IEC 60664-1

##### ⑤ Pollution degree

Pollution degree : degree 4 according to IEC 60664-1 (Both of PJID143 and JC928(CE)).

#### 4. APPLICATIONS

Tightening and loosening of the following fasteners.

- Screws
- Bolts

#### 5. ABOUT PRODUCTION YEAR

This product bears production number in the body.(Fig.A12) The two digits of the number from left indicates the production year.

(Example)

10826035D

↑  
Year 2010



### CAUTION

- Regarding the screw fastening times per charge, it depends on the condition of the Battery pack, hardness of the material and the operating temperature.

The following chart is based on the brand-new battery and fastening in wood (Hemlock).

Screw/Bolt	Diameter	Length	Fastening times
Screw	4.2mm	65mm	Apprx. 315
	4.5mm	90mm	Apprx. 190
Bolt	M8	16mm	Apprx. 2.100



### CAUTION

- When operating the tool continuously using a spare battery pack, allow the machine to rest for approximately 15 minutes before starting operation with the spare. If the above is not observed, the motor, trigger switch and other parts may burn out.

## 8. REFERENCE VALUES FOR SCREW / BOLT FASTENING (TIGHTENING TORQUE)

The appropriate torque for a screw/bolt differs according to the material and size of the screw/bolt, and the material being screwed. The following figures show the relation between torque tightening screws/bolts and operating time. Refer to them and optimize your operating time.

### <Tightening conditions>

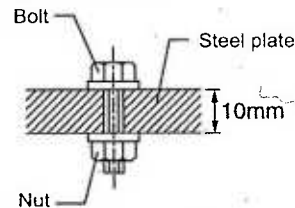

- \* The following bolts are used.  
Standard bolt: Strength category 4.8  
High-tensile bolt: Strength category 12.9

### Strength category

4.8

- Bolt yielding point (80% of tensile strength)  
314 N/mm<sup>2</sup> (32 kgf/mm<sup>2</sup>)
- Bolt tensile strength 392 N/mm<sup>2</sup> (40 kgf/mm<sup>2</sup>)

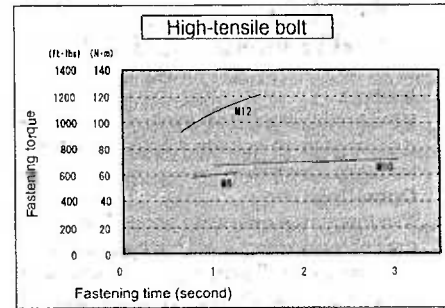
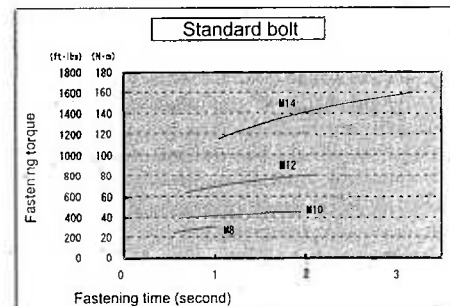

### CAUTION

- Small screws should be tightened by adjusting the amount that the trigger switch is pulled.
- Because excessively long operating periods may stretch or break small screws, be sure to check the operating time and tightening torque before starting operation.
- Tighten with the tool lined up straight with a screw.  
Tightening the screw with the tool at an angle to the screw will prevent the transmission of the correct level of torque produced by the tool. Doing so can also damage the head of the screw, and cause the tip of a bit to wear down.
- Use a bit that matches the head of the screw.
- The maximum tightening torque of this tool was measured when a M14 high-strength bolt (strength category: 12.9) was tightened for 3 seconds. Note that this measurement condition is outside of the tool specifications.

## 6. FACTORS THAT AFFECT TIGHTENING TORQUE

- Voltage**  
If the battery reaches the margin of complete discharge level, voltage drops and tightening torque is lowered.
- Operating time**  
The longer the operating period, the greater the tightening torque will become, but only to a certain level. Extending the operating period cannot cause the level to be transcended. The appropriate tightening torque required for a screw or a bolt differs according to the material, size and grade of the screw/bolt. Be sure to apply an operating period and torque that are suitable for the screw/bolt. If an excessively large torque is applied to a small screw or bolt, it may stretch or break.
- Diameter of screw/bolt**
  - Screws/bolts with different diameters have the different torque coefficient (A coefficient determined by finished conditions of the bolt. Indicated by bolt manufacturers). Even in the same grade, screws/bolts with different diameter require different tightening torque.
  - Even with the same diameter, the required tightening torque differs according to its torque coefficient (A coefficient determined by finished conditions of the bolt. Indicated by bolt manufacturers), grade or length.
- Workpiece**  
When a bolt is tightened into wood or another type of soft material, tightening torque is reduced significantly compared with the case where the bolt is tightened into an iron frame or other type of hard material.
- Bit**  
Inappropriate selection of a bit that is not suitable for screw or bolt reduces tightening torque.
- Trigger switch**  
Slightly pulling the trigger switch (not full power) reduces tightening torque.

# PJID143(CE)

EXPLODED  
VIEW AND SPARE  
PARTS LIST

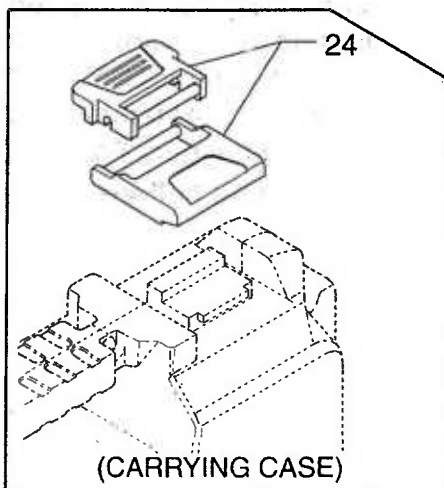
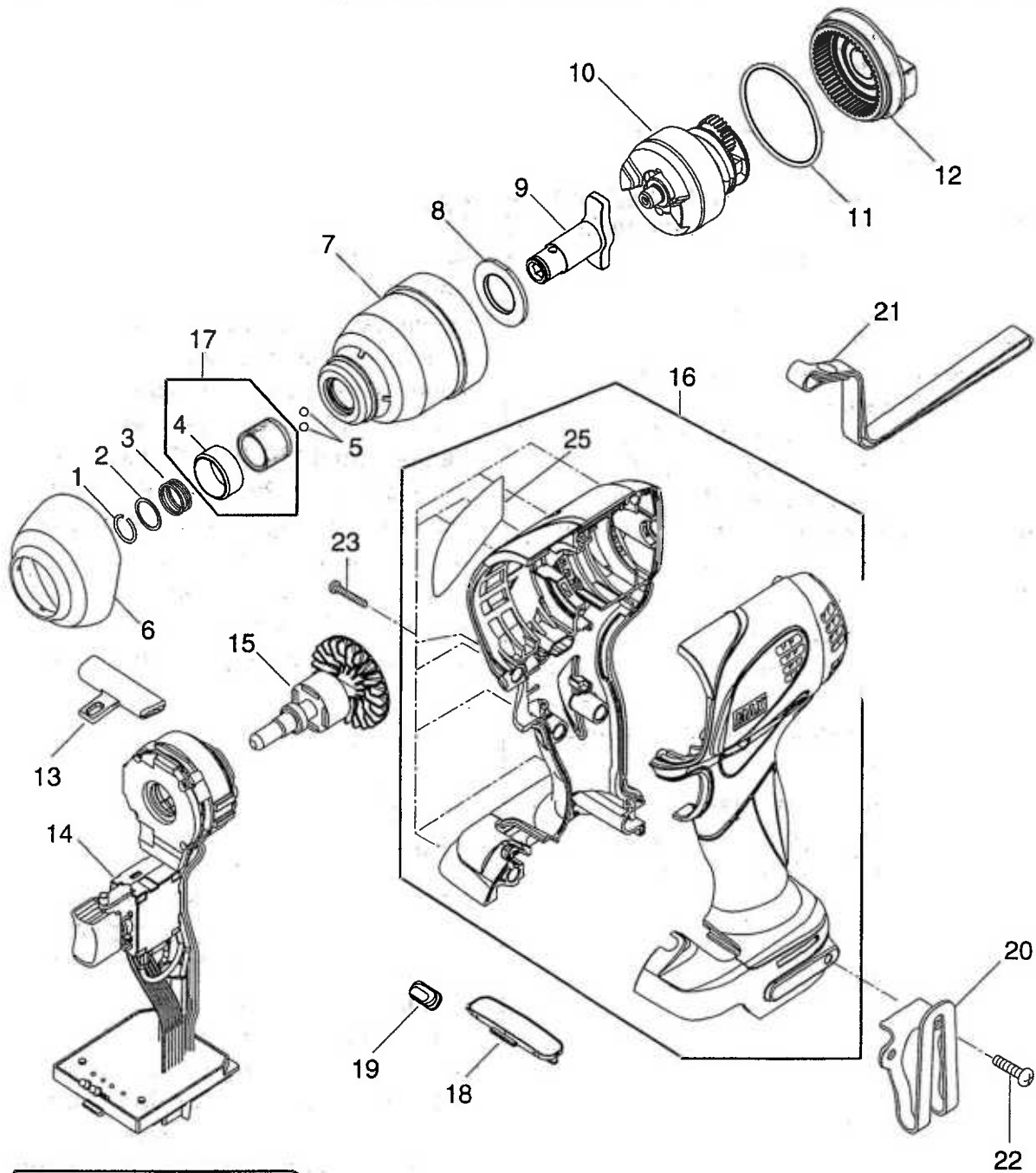







APRIL 2012

PJID143(CE)

ITEM NO.	PART NO.	MATERIAL	ENGLISH
1	PJ10517	Steel	Retaining Ring
2	PJ10516	Steel	Washer C
3	PJ10515	Steel	Guide Spring
4	PJ11833	Elastomer	Sleeve Protector
5	LL71704	Steel	Steel Ball
6	PJ11960	Elastomer	Protector
7	PJ70162	Aluminium, Steel	Hammer Case Unit
8	PJ11952	Nylon	Bumper
9	PJ12723	Steel	Anvil
10	PJ70160	Steel	Impact Assy
11	HH11188	Rubber	O-ring A S45
12	PJ70176	Nylon, Steel	Inner Gear Unit
13	PJ11987	Nylon	Rotational Direction Switch
14	PJ80037		Control Unit
15	PJ70155		Rotor Unit
16	PJ70239	Nylon, Elastomer	Housing L/R Set
17	PJ70177	Steel, Elastomer	Guide Sleeve Unit
18	PJ70195	ABS, PET	Panel Assy
19	PJ10494	Polycarbonate	Light Cover
20	PJ11979	Steel	Belt Hook
21	PJ10522	Nylon	Carrying Strap
22	AA25902	Steel	Screw
23	AA05589	Steel	Tap Tight (B) 3X16 CF
24	PJ70058	Polypropylene	Latch Assy
25	PJ12724	PET	Specification Label

## INDICATION OF QUICK CHARGER LAMPS

Charger LED lamp	Buzzer sound	Recharging status	
Red lamp blinks. It blinks every second. 	The power cord is plugged into the receptacle. Two short beeps (Pi, pi)	The charger is powered.	The charger power cord is plugged into a wall socket.
Red lamp lights. It remains lit. 	The battery pack is mounted. One short beep (Pi)	The battery is being recharged.	Quick recharging continues.
The green lamp blinks. It blinks every second. 	The battery has been recharged. A long beep for approx. 2 seconds (Piii...)	The battery has been recharged.	The battery has been recharged to approx. 90% of its capacity. If you leave the battery pack on the charger, recharging will continue.
The green lamp lights up. It remains lit. 	Fully recharged. A long beep for approx. 2 seconds (Piii...)	Battery is "fully" recharged.	Recharged to 100% capacity.
The red lamp lights up. The orange lamp lights up. They remain lit. 	—	Protective charging	The battery is recharged with a low current to protect the charger and battery.
The orange lamp lights up. It remains lit. 	—	Standby	If the temperature of the battery pack is too high: Battery recharging starts automatically when the temperature drops below the limit. If the temperature of the battery pack is too low: Place the battery pack in a room temperature location for a while, then retry recharging it.
The orange lamp blinks. It blinks quickly (0.1 sec ON and 0.1 sec OFF). 	Not possible to recharge. Short continuous beeps for approx. 10 seconds (Pi, pi, pi, pi,...)	Not possible to recharge.	Unable to recharge the battery. The battery pack slot is contaminated, or the battery pack has failed.

\* For batteries those are at low temperatures (10°C (50°F) or lower), charging time must be extended longer.

### For the JC928 lithium ion battery charger (CE)

"Power Supply Cord: Use UL Listed and CSA Certified detachable power supply cord, 18 AWG, two conductors, cord rated VW-1, 105°C, cord external length minimum 1.8m.

One end terminates in a molded-on attachment plug with a 15 A, 125 V (NEMA 1-15P) or 15 A, 250 V (NEMA 2-15P) type configuration.

Other end terminates in a molded-on connector which mates with the Power Appliance Inlet.

If a flexible power supply cord is required, the appropriate cord (see below) must be used.

The SP-2, SPE-2, SV, SVE, or SVT flexible power supply cord can be used."